

고객용 도면

제어계통도 / BSMS (Battery Swapping Management System) (배터리 스와핑 관리시스템)

제품1 / 형번 : BSMS-300W-25V --> (공칭 24~50V 배터리) to (공칭24~25V) 배터리 / 10A Buck Boost Charger
 제품2 / 형번 : BSMS-300W-50V --> (공칭 24~50V 배터리) to (공칭48~50V) 배터리 / 3~5A Buck Boost Charger

2024.06.28

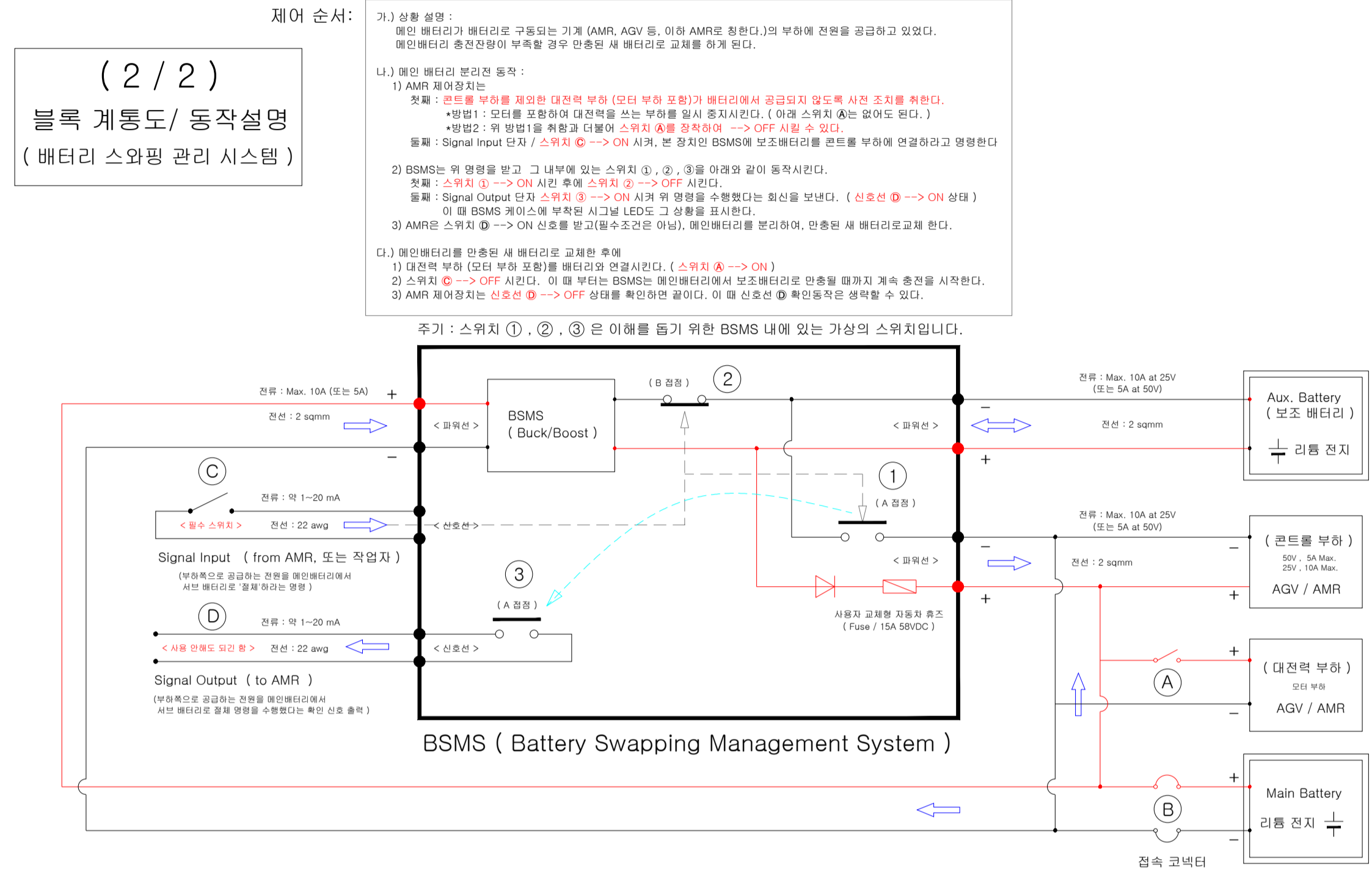

고객도면 / BSMS (Battery Swapping Management System) (배터리 스와핑 관리시스템)

제품1 / 형번 : BSMS-300W-25V --> (공칭 24~50V 배터리) to (공칭24~25V) 배터리 / 10A Buck Boost Charger
 제품2 / 형번 : BSMS-300W-50V --> (공칭 24~50V 배터리) to (공칭48~50V) 배터리 / 3~5A Buck Boost Charger

2024.01.08

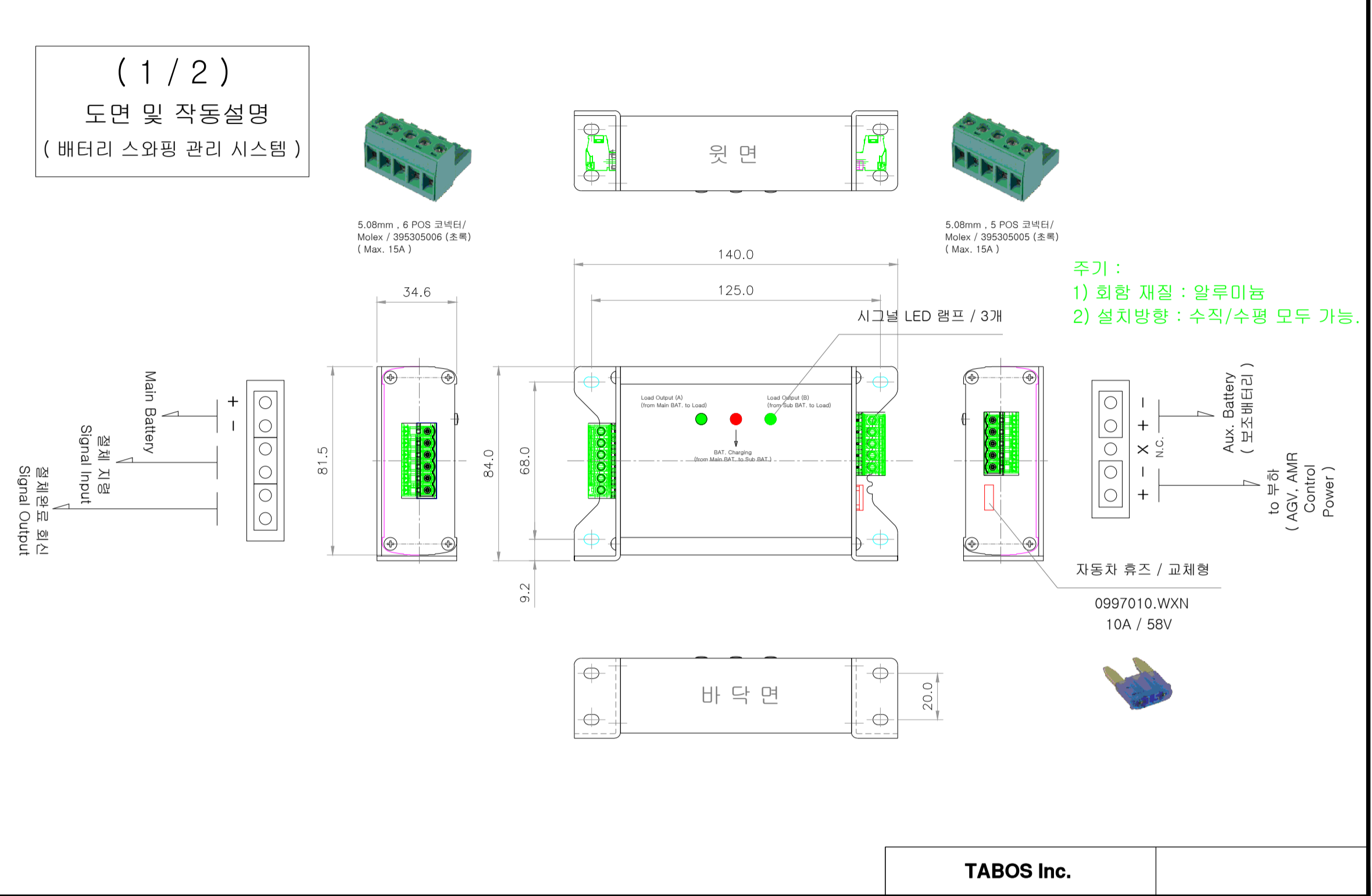

고객도면 3D / 2023.07.19

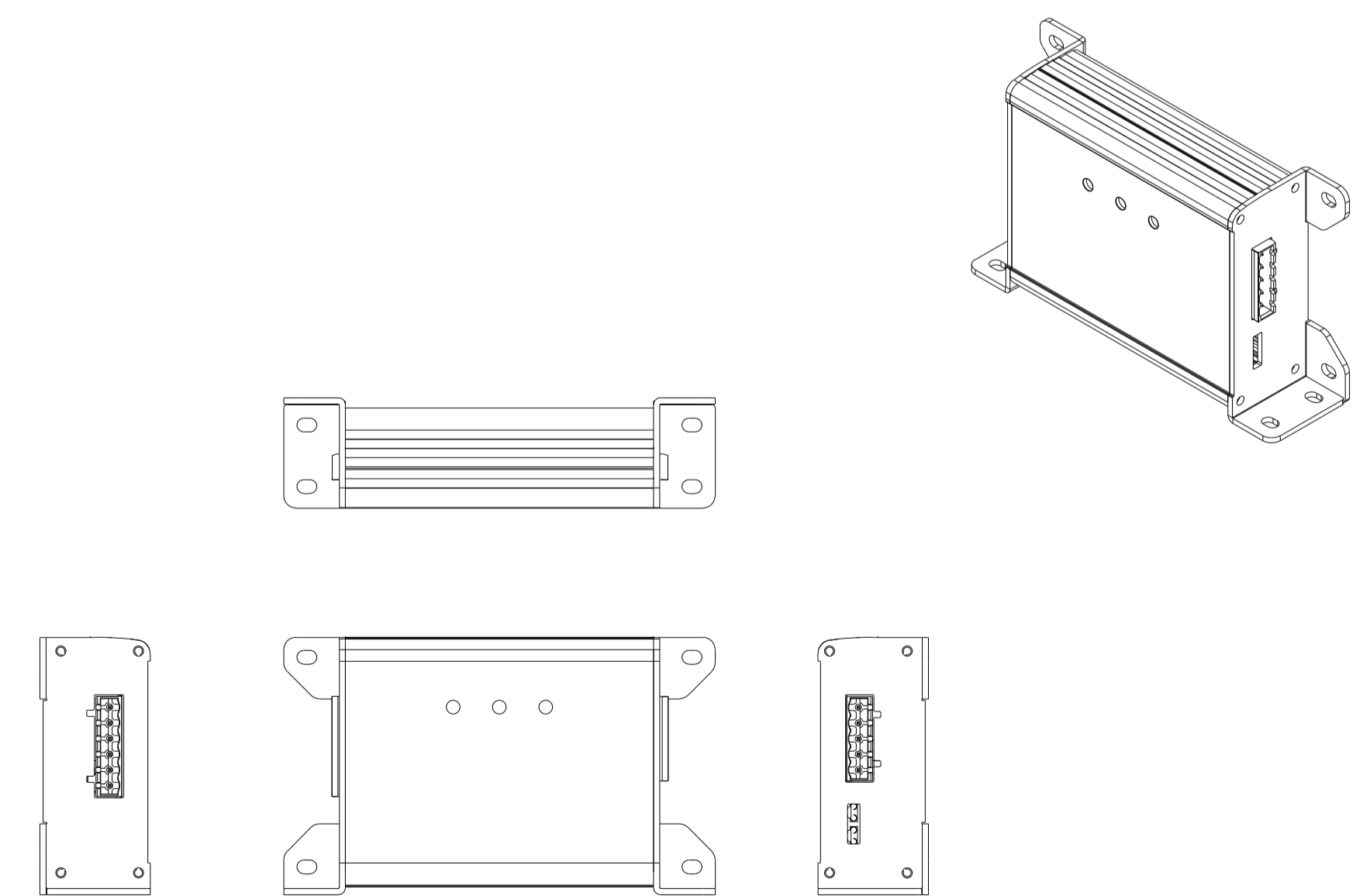

TABOS Inc.