

Lithium battery Chargers

700W / 1500W

(Industrial / Indoor / Stationary Equipment)

For Lithium Ion / Lithium Polymer battery only

For AC 220V only

Bidirectional control of external communication for automation system (option)

CE (for several models)



1500W charger

700W charger

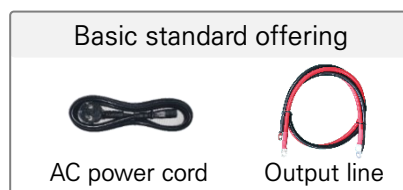

Table of Contents

0. Important Notices.....	3
How to Select Charging Voltage	3
Cautions when using Chargers.....	3
Cautions on the Type and Capacity of Lithium Ion battery	6
Cautions on the Capacity of the Lithium Battery to be applied.	6
1. Specifications – 700W Series	7
2. Specifications – 1500W Series	9
3. Common Specifications for all models	11
Charge current Adjustment Function	11
Bidirectional Communicating Function (COM) – Option	11
Charger and Lithium Battery Charging Characteristics	15
Characteristics of electric circuit	15
Procedures of Charge	15
Other Specification for Safety and Convenience.....	16
4. Model Number / Order Code / Option Marking.....	17
5. Selecting Connector Options.....	17
6. Product Drawings.....	18

0. Important Notices

How to Select Charging Voltage

Type	Charger Max. charging voltage	Approximate amount of charging	Considerations when selecting charging voltage
25V Battery (7S, 7 series)	28V	80%	Applied when the electric equipment installed in the load generates an error due to overvoltage at 29V *In case of AGV, this voltage range is selected generally.
	29V	90%	To maximize battery utilization. This could be applied if no problem occurs.
50V Battery (14S, 14series)	56V	80%	Applied when the electric equipment installed in the load generates an error due to overvoltage at 29V *In case of AGV, this voltage range is selected generally.
	58V	90%	To maximize battery utilization. This could be applied if no problem occurs.

Cautions when using Chargers

IMPORTANT CAUTIONS

-  When applying to an automatic charging station of an AGV (Automatic Guide Vehicle), Do not turn ON / OFF the AC input power to turn ON / OFF chargers. Because the Firmware (S / W) of the charger may malfunction in some cases.
It will operate automatically if the AC input power is always set to ON.

This charger detects the battery and charges it automatically only when the battery is connected. In other words, when the battery is not connected, there would be no outputs.

-  **Do not turn ON / OFF the AC input power to turn ON / OFF chargers.**
When applying to an automatic charging station of an AGV (Automatic Guide Vehicle), Do not turn ON / OFF the AC input power to turn ON / OFF chargers. Because the Firmware (S / W) of the charger may malfunction in some cases. It will operate automatically if the AC input power is always set to ON.

-  **When the battery is not connected, there would be no outputs.**

This charger detects the battery and charges it automatically only when the battery is connected.

 **When cannot boot powered on AC (No durability issues)**

When power is applied, it is recommended to observe the following procedure.

- 1) When 220V AC power is applied, the switch must be OFF.
- 2) Turn on the switch after turning on the power.

* If there is no response from the above,

- 3) After the power switch is off and 220V AC is shorted, wait until the internal capacitor is fully discharged. (maximum 1 minute)
 - 4) After waiting, try again in the above order,
- If there is no response afterwards, please fill out the application form and send it to us.

 **Make sure the applied battery is suitable for the charger.**

Do not connect lead acid storage batteries. The charging voltage specification may not be suitable for the charger. The charger can be used only when the charging voltage of it is lower than the maximum voltage of the battery. Connect +, - on the output terminal block to the battery terminal.

 **Compared to electric current, the use of thin wires causes fire accidents due to deterioration of wires and connectors in the long term.**

In addition, in the case of a charging line, it is necessary to use an appropriate wire thickness to reduce the voltage drop so that charging can be performed in accordance with the target value.

The wire thickness is determined by the size of the current used.

◇ **AC input power line:**

Calculation formula for allowable current per wire thickness of AC input wire: minimum 5A / mm² (SQMM).

In a room temperature environment, the permissible current per 1mm² (square millimeter) of wire can be calculated as about 5A.

If the ambient temperature is above 40 degrees, you may also need to use thicker wire than the above calculation.

However, this regulation is related to safety, such as heating of wires.

If the maximum AC input current is 8A → Minimum $8/5 =$ Minimum 1.6 mm² or more

◇ **DC Battery Charging Line:**

Calculation formula for allowable current per wire thickness of charging line: minimum 3A / mm² (SQMM). (Condition: When the length of the charging cable is less than 2m)

This regulation is recommended by Tabos. If the charging line is thin, a voltage drop will occur. Even if the voltage drop is only 0.5V

The battery charge is low. This is a regulation to reduce the amount of voltage drop in the wire when charging so that the charging works well in the target range.

If the length of the charging line is longer than 2~3m, a lot of voltage drop occurs during charging, so you should use a wire thicker than the wire thickness calculated above. If the ambient temperature is above 40 degrees, you may also need to use thicker wire than the above calculation.

If the charging current is 50A --> Minimum $45 / 3 =$ Minimum 15 mm² or more --> Select standard wire 16 or 25 mm² wire.

If the charging current is 25A --> Minimum $25 / 3 =$ Minimum 8 mm² or more --> Select standard wire 10 mm² wire.

 **The ability of the charger to recharge when the battery voltage drops after the battery is fully charged .**

With the charger and battery connected at all times

The battery can be used in conjunction with a load device.

At this time, the charger resumes charging operation when the battery falls below a certain voltage. This voltage is called the recharge start voltage.

- * Model : TC-700W-25V□□A → The recharge start voltage = Around 27V
- * Model : TC-1500W-25V□□A → The recharge start voltage = Around 27V
- * Model : TC-700W-50V□□A → The recharge start voltage = Around 55V
- * Model : TC-1500W-50V□□A → The recharge start voltage = Around 55V

 **Depending on the operating state of the charger, the LED signal will light up as shown below.**

- ◇ Green(●) : Charging completed
- ◇ Red(●) : Normal charging state
- ◇ Orange(●) : battery warning
- ◇ Orange flickering (●●●●···): battery changes polarity
- ◇ Red, Green flickering alternately (●●●●···): Flashes 3 to 4 times per second.
Normal operation for fine charging after under voltage state.
After several minutes, it turns red and charges normally.
- ◇ Green flickering(●●●●···): Standby state when battery is not connected / or Fine charging state.
- ◇ If there is a lot of heat in the connected lithium battery, stop charging. check again and recharge.

Cautions on the Type and Capacity of Lithium Ion battery

Cautions on the Maximum Voltage of Lithium Battery.

The maximum voltage for lithium batteries in 7 series, varies depending on the manufacturer and may be 29.4 V or 30.1 V or more. 'TC-1500W-25V45A / Max29V' charger charges up to 29V. So if the maximum voltage of the battery is 30.1V or higher, it will charge about 5% less. But there is no problem to use.

Caution : Do not connect this charger with the maximum voltage of the lithium battery itself less than 29.4V.

Cautions on the Capacity of the Lithium Battery to be applied.

Maximum charge current when considering only lithium battery cell

It is recommended to charge with maximum current to 0.5C or less. If the capacity of the lithium battery is 20Ah, 0.5C charging means charging with current less than 10A (= 20Ah x 50%) which is less than 50% of the battery capacity. Typical lithium ion battery cells can be charged up to 1 C, but this is the maximum value. We recommend 0.5 C or less for safety and long life.

However, this also depends on the lithium ion battery pack product, and the maximum charge current specifications are listed on each battery pack. Exceeding this value may cause the battery to malfunction, deteriorate its life, or sometimes overheat and damage it. Please refer to lithium battery manufacturer's charge current specification. Some lithium batteries may be available for charging up to 1C.

Maximum charge current considering capacity of BMS

You must charge below the maximum charge current value set by BMS.

Some companies' lithium batteries can accumulate heat in the BMS when charged with the maximum charge current specified in the specification, which can cause the battery to overheat or accidents.

If it is not urgent, it is recommended to charge the battery slowly by reducing the charge current.

Our chargers are designed to reduce the charge current by considering the above problems.

1. Specifications – 700W Series

	Model name	Standard model	TC-700W-25V25A /Max29V	TC-700W-25V25A /Max28V	TC-700W-50V13A /Max58V	TC-700W-50V13A /Max56V
		Communication port (RS232C)	TC-700W-25V25A /Max29V/COM	TC-700W-25V25A /Max28V/COM	TC-700W-50V13A /Max58V/COM	TC-700W-50V13A /Max56V/COM
0	Certification					
1	Batteries	At room temperature	At least 8 mm ²		At least 5 mm ²	
2	Batteries	Li-Ion/Polymer	7 Series(7S), 25.2V or more, 29.4V charging max.		14 Series(14S), 50.4V or more, 58.8V charging max.	
3	Charging Voltage	Battery Max.Voltage when fully charged	29.0 VDC	28.0 VDC	58.0 VDC	56.0 VDC
4	Application	Considering acceptable Max.Voltage by the load	Standard	Recommended for Factory Automation, AGV Battery Systems	Standard	Recommended for Factory Automation, AGV Battery Systems
5	Charging Capacity	Full Charged Capacity	About 90%	About 80%	About 90%	About 80%
6	Charge current		Max. 27A±0.5A, (current ripples : under 3%) 4-steps current adjustment(13, 17 , 21, 27A)		Max. 13A±0.3A, (current ripples : under 3%) 4-steps current adjustment (6, 8, 10, 13A)	
7	Finishing Current		Approximately 10 – 20% of the normal charge current max. (Current that stops charging)			
8	How to Charge		CC/CV (Constant Current/ Constant Voltage), 4-steps current increase after charging starts (Slow Start)			
9	Type of Charger	Insulated	Primary/Secondary Insulated chargers (Safety management and noise reduction in case of ground fault)			
10	Input Voltage	RMS	180VAC ~ 240VAC / 50~60 Hz			
11	Input Power	RMS	About 887 VA	About 918 VA	About 816 VA	About 743 VA

	Model name	Standard model	TC-700W-25V25A /Max29V	TC-700W-25V25A /Max28V	TC-700W-50V13A /Max58V	TC-700W-50V13A /Max56V
		Communication port (RS232C)	TC-700W-25V25A /Max29V/COM	TC-700W-25V25A /Max28V/COM	TC-700W-50V13A /Max58V/COM	TC-700W-50V13A /Max56V/COM
12	Recommended Circuit Breaker(CB)	5A Circuit Breaker(CB) , considering surge current peak max. at initial start of chargers				
13	Standby Power	RMS	17W	←	←	←
14	Charging Power	RMS	756W max.	783W max.	728W max.	754W max.
15	Efficiency/PF		Efficiency 87% , Power Factor 98%		Efficiency 91% , Power Factor 98%	
16	Protection Features	Short circuit protection / over current protection / over voltage protection / reverse connection prevention / pre-charging / *BMS/PCM unblocking feature * BMS/PCM : Battery Management System / Protection Circuit Module				
17	Temperature	Operation : -20°C ~ +40°C / Storage : -20°C ~ +65°C				
18	Size / Weight	W 140mm x H 77mm x L 340mm , 3.5Kg				

* Please refer to the separate manual on the website for the communication protocol related to the communication port mounting type.

2. Specifications – 1500W Series

	Model name	Standard model	TC-1500W-25V45A /Max29V	TC-1500W-25V45A /Max28V	TC-1500W-50V25A /Max58V	TC-1500W-50V25A /Max56V
		Communication port (RS232C)	TC-1500W-25V45A /Max29V/COM	TC-150W-25V45A /Max28V/COM	TC-1500W-50V25A /Max58V/COM	TC-1500W-50V25A /Max56V/COM
0	Certification	CE	CE			
1	Output Wire Size	At room temperature	At least 16 mm ²		At least 8 mm ²	
2	Batteries	Li-Ion/Polymer	7series(7S), 25.2V or more, 29.4V charging max.		14series(14S), 50.4V or more, 58.8V charging max.	
3	Charging Voltage	Battery Max.Voltage when fully charged	29.0 VDC	28.0 VDC	29.0 VDC	28.0 VDC
4	Application	Considering acceptable Max.Voltage by the load	Standard	Recommended for automation power supply	Standard	Recommended for automation power supply
5	Charging Capacity	Full Charged Capacity	About 90%	About 80%	About 90%	About 80%
6	Charge current		Max. 45A±0.5A , (current ripples : under 3%) 4-steps current adjustment (18, 25 , 33, 45A)		Max. 25A±0.5A, (current ripples : under 3%) 4-steps current adjustment (13, 17 , 21, 25A)	
7	Finishing Current		Approximately 10 – 20% of the normal charge current max. (Current that stops charging)			
8	How to Charge		CC/CV (Constant Current/ Constant Voltage), 4-steps current increase after charging starts (Slow Start)			
9	Type of Charger	Insulated	Primary/Secondary Insulated chargers (Safety management and noise reduction in case of ground fault)			
10	Input Voltage	RMS	180VAC ~ 240VAC / 50~60 Hz			

	Model name	Standard model	TC-1500W-25V45A /Max29V	TC-1500W-25V45A /Max28V	TC-1500W-50V25A /Max58V	TC-1500W-50V25A /Max56V
		Communication port (RS232C)	TC-1500W-25V45A /Max29V/COM	TC-150W-25V45A /Max28V/COM	TC-1500W-50V25A /Max58V/COM	TC-1500W-50V25A /Max56V/COM
11	Input Power	RMS	About 1,332 VA	About 1,286 VA	About 1,332 VA	About 1,286 VA
12	Recommended Circuit Breaker(CB)		10A Circuit Breaker(CB) , considering surge current peak max. at initial start of chargers			
13	Standby Power	RMS	30W	←	30W	←
14	Charging Power	RMS	1,500W Max.	1,448W Max.	1,500W Max.	1,448W Max.
15	Efficiency/PF		Efficiency 87% , Power Factor 98%		Efficiency 91% , Power Factor 98%	
16	Protection Features		Short circuit protection / over current protection / over voltage protection / reverse connection prevention / pre-charging / *BMS/PCM unblocking feature * BMS/PCM : Battery Management System / Protection Circuit Module			
17	Temperature		Operation : -20°C ~ +40°C / Storage : -20°C ~ +65°C			
18	Size / Weight		W 180mm x H 86mm x L 410mm , 5.5Kg			

* Please refer to the separate manual on the website for the communication protocol related to the communication port mounting type.

3. Common Specifications for all models

Charge current Adjustment Function

Refer to Product Drawings section.

Turning the current adjustment volume to the left decreases the charge current, and turning it to the right increases it. (Multilevel adjustment type).

During charging, you can adjust the current by turning the volume and it will be reflected a few seconds later. The volume is initially set to the maximum right of the volume and can be reduced.

The charge current adjustment volume can be reduced to 60% of the rated charge current.

Bidirectional Communicating Function (COM) – Option





COM (option) – RS232C communication support (Recommended for automation power supply)

〈 charger → upper stage controller 〉 contents of transmission : Charger operating status, etc.

〈 upper stage controller → charger 〉 contents of transmission : Charge start, Charge end, etc.

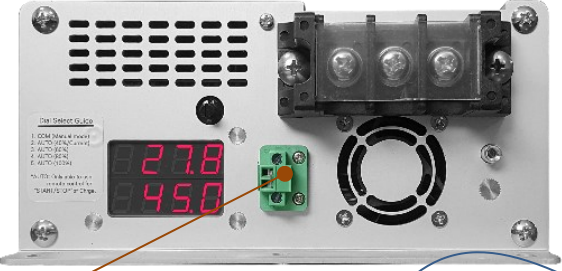
* Please refer to the attached document for detailed communication protocol specifications. (Download from Tabos website)

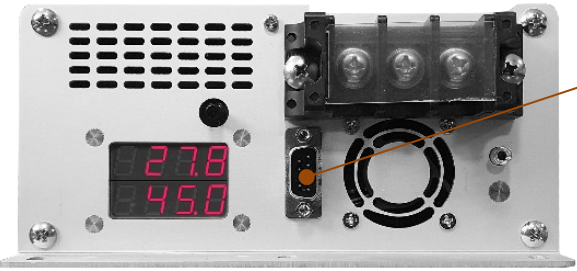
How to use the 1500W charger

Basic Model	
 <p>[Rear : Charging Output (DC)]</p>	 <p>[Line Input (AC)]</p>
<p>* Use of green connector : When this connector (2 poles) is short-circuited, the pre-charging function is activated. If OPEN is selected, the <u>pre-charging function</u> is disabled and the main charge is directly entered.</p>	<p>Description of pre-charging function: When the battery is over-discharged, pulse charging is performed at 1~2A, and when the battery is revived, it detects the battery voltage and</p>
Optional model “ / COM” Communication D-sub 9pin Port	
 <p>[Rear : Charging Output (DC)] (D-Sub 9 pins Communication Ports / RS232C</p>	 <p>[Line Input (AC)]</p>

How to adjust the charging current (충전전류 조정 방법)

Turning the rotary switch to the right as far as possible sets the maximum charging current.
At this time, the charging current for each model is as follows.

(로터리 스위치를 오른쪽으로 최대한 돌리면 최대충전전류로 세팅된다.
이 때 각 모델 별 충전전류는 아래와 같다.)

TC-1500W - 50V 25A Model --> Charging Current 25A setting
TC-1500W - 25V 45A Model --> Charging Current 45A setting



(700W)



(1500W)

(Cautions)

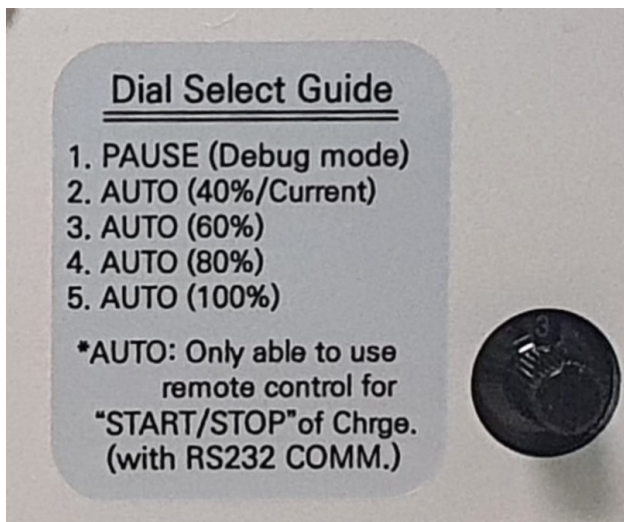

(Detailed photo of the rotary switch)

Ex. : 700W Charger

For model "TC-700W-25V25A"

The maximum charging current is 30A.

Turn the rotary switch to '2':

Charging current 30A x 40% =
approximately 12A

Turn the rotary switch to '3':

Charging current 30A x 60% =
approximately 18A

Turn the rotary switch as far to the right as possible and then turn it to the left one click at a time to lower the charging current by that much.

However, the position where it no longer turns to the left is for using the communication port. Therefore, when setting the charging current, the lowest current setting position is the position where you turn as far left as possible and then turn right by 1 click.

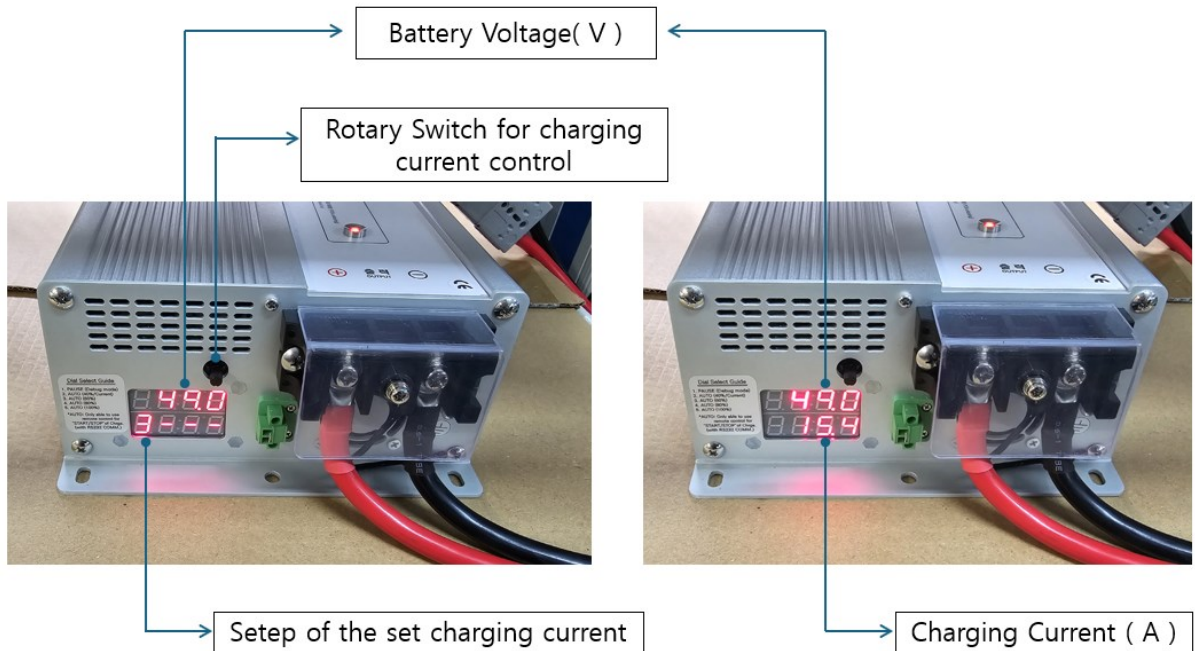

This number changes when you turn the 'rotary switch'

Note : <Set charging current level> and <Current charging current> display alternately at 2-second intervals.

Charger and Lithium Battery Charging Characteristics

Data of products manufactured by Tabos.

◇ Charging time calculation

$$= \text{Amphere hour of Li-Ion Battery (Ah)} / \text{Charge current (A)} \times \text{Correction factor(1.1)}$$

$$= 104\text{Ah} / 45\text{A} \times 1.1 = 2.5 \text{ hour}$$

◇ Elapsed time from initial charge to normal charge / 1500W Charger

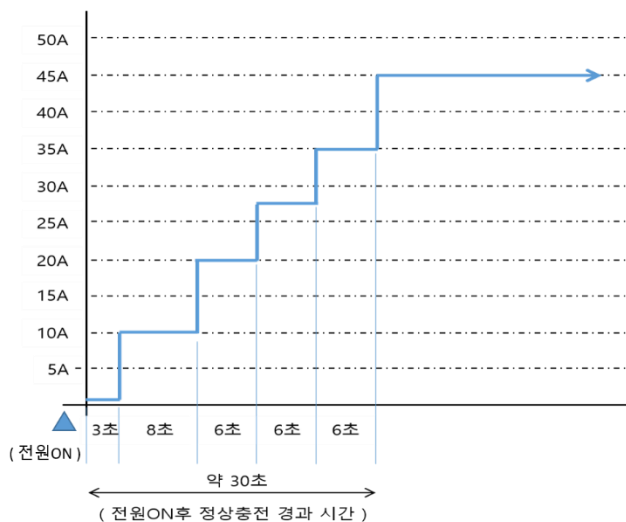

This chart can be implied to 700W charger as well. Elapsed time could be slightly changed according to circumstances.

Characteristics of electric circuit

◇ LLC Resonant converter type

Soft Switching [ZVS(Zero Voltage Switching) and ZCS(Zero Current Switching)] is possible.
Minimized current noise, controlled heat, increased durability.

◇ Mi-com mounted

Optimum charging performance.
Increased safety and stability.

Procedures of Charge

◇ When the battery is not connected, no electricity is output from the output terminal.

◇ Pre-Charging Function

After the battery is connected, the charger detects the battery voltage and starts charge with the low current when the voltage is lower than normal. (The signal LED lamp flickers alternately between red and green until voltage back to be normal.) This function is implemented only when voltage of the battery is abnormally low. This is to protect the battery and ensure safety.

◇ Soft Start function

If voltage of the battery connected to the charger is within the normal range, it starts to charge by gradually increasing the current in several steps. This is particularly useful when charging batteries mounted on Automatic Guided Vehicle(AGV). When an AGV arrives at home position and is connected to the charger, it can be charged reliably without electrical sparks.

◇ Constant Current Charge

The battery is charged with constant current (CC) until full charge.
For example, the TC-1500W-25V45A / Max29V will continue charging at about 45A.

◇ Constant Voltage Charge

When the battery reaches the full charge voltage, it is charged in the constant voltage (CV) mode. After the battery charged with maximum current that does not exceed full charge voltage, the charge current is gradually decreased.
When the charge current is gradually reduced to 10 ~ 20% of the rated charge current (varies by model), it is recognized as a full charge and the charging is stopped. At this time, all operations of charger and fan stops.

Other Specification for Safety and Convenience

◇ Short-Circuit Protection and Automatic Return

The output line automatically detects the short-circuit and cuts off the output. When the problem is solved, it returns.

◇ Under/Over Voltage Protection.

The primary AC power stage and the secondary output DC power stage are electrically isolated.

◇ Reversed Polarity Detecting Device,

The battery and charger will not fail even if the + / - is changed and connected. In this situation, The orange lamp of the signal LED flickers until the user corrects the wiring.

◇ Monitoring display:

Indication of charge voltage and charge current
Inform of the abnormality.

◇ Charge current adjustment : Current adjustment function through volume knob.

4. Model Number / Order Code / Option Marking

① ② ③ ④ ⑤

TC- 700W – 25V 25A / Max29V / COM

TC-1500W – 25V 45A / Max29V / COM

TC-1500W – 25V 45A / Max28V

①	Series name	TC-700W , TC-1500W
②	Battery nominal voltage	25V : for 7 series battery (nominal 25.2V / 29.4V charge max.) 50V : for 14 series battery (nominal 50.4V / 58.8V charge max.)
③	Charge Current Rating	Classification of Charge Current amount
④	Maximum charge voltage	Customers' selection
⑤	Communication port (option)	COM : Bidirectional Communication (RS232C) Charge start command, charge end command, charge current control command, and monitoring information. <i>* D-Sub 9-pin (Male / Male) connector next to output terminal block</i>

5. Selecting Connector Options

<p>SB50A-Gray-M4-800L (for 700W)</p> <p>SB50A-Gray-M6-800L (for 1500W)</p>	<p>1) 50Ah, Terminal for M4 and M6, wire length 800mm,</p> <p>2) Connector : Compatible with Anderson SB50A grey These connectors are connected to each other with the same connector pair without male and female, and they must be inserted only in the direction in which the +/- are matched.</p> <p>3) Output wire combination example * 2 Purchases example: 1 battery, 1 charger * 3 Purchases example: 1 battery, 1 charger, 1 load side <i>* Note: 700W charger terminal is M4, 1500W charger is M6, Tabos batteries are typically M6.</i></p>	
--	---	---

6. Product Drawings

700W (All models are common)

